

COMPACT & ROBUST FREQUENCY-STABILISED LASER

FLAME is a compact, frequency-stabilised laser module with integrated vapour cell that allows locking to spectral features of an atomic reference. This first FLAME product addresses transitions of Rubidium around 780 nm that are key to applications in Quantum Technologies.

While the underpinning scientific principles behind many Quantum Technology applications are well understood, practical implementation has proved challenging until now. For Quantum Technology to fulfil its potential requires orders of magnitude reduction in size, weight, power-consumption and cost compared to many of the current generation of laboratory demonstrators. In addition, the instrument must be reliable in real-world environments where it will be exposed to vibrations, shocks and temperature changes during operation.

The FLAME laser meets these challenges by moving beyond the

established norms of laboratory-based scientific lasers and instead making use of packaging techniques more normally employed in the manufacture of high reliability telecoms devices. Optocap's space-qualified processes are utilised to minimise size and maximise stability and reliability.

The resulting laser module lends itself to usage in applications both in the lab, and within robust portable instruments. The FLAME is ideally suited for use in laser cooling, trapping and repumping. These operations are key to many Quantum Technology applications based upon cold atoms, such as atomic clocks, gravimeters and inertial navigation units.

The 780nm FLAME laser is the first product in Optocap's new Narrow-Linewidth Lasers product line. Contact us at info@optocap.com for more details and to discuss your requirements for FLAME and for narrow-linewidth lasers in general.

FLAME

FREQUENCY-STABILISED LASER MODULES WITH INTEGRATED REFERENCE CELL

The FLAME product has been developed in conjunction with Optocap's technology partner, Fraunhofer UK, at the Fraunhofer Centre for Applied Photonics, Glasgow UK.



The FLAME development programme was initiated with support from Innovate-UK.

Innovate UK

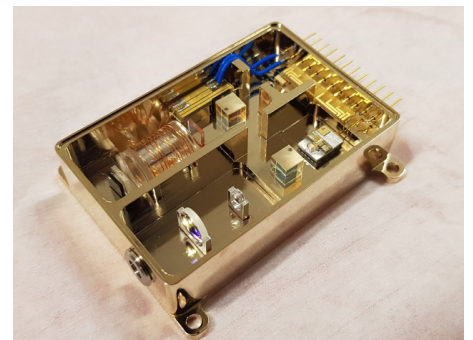



Preliminary Draft

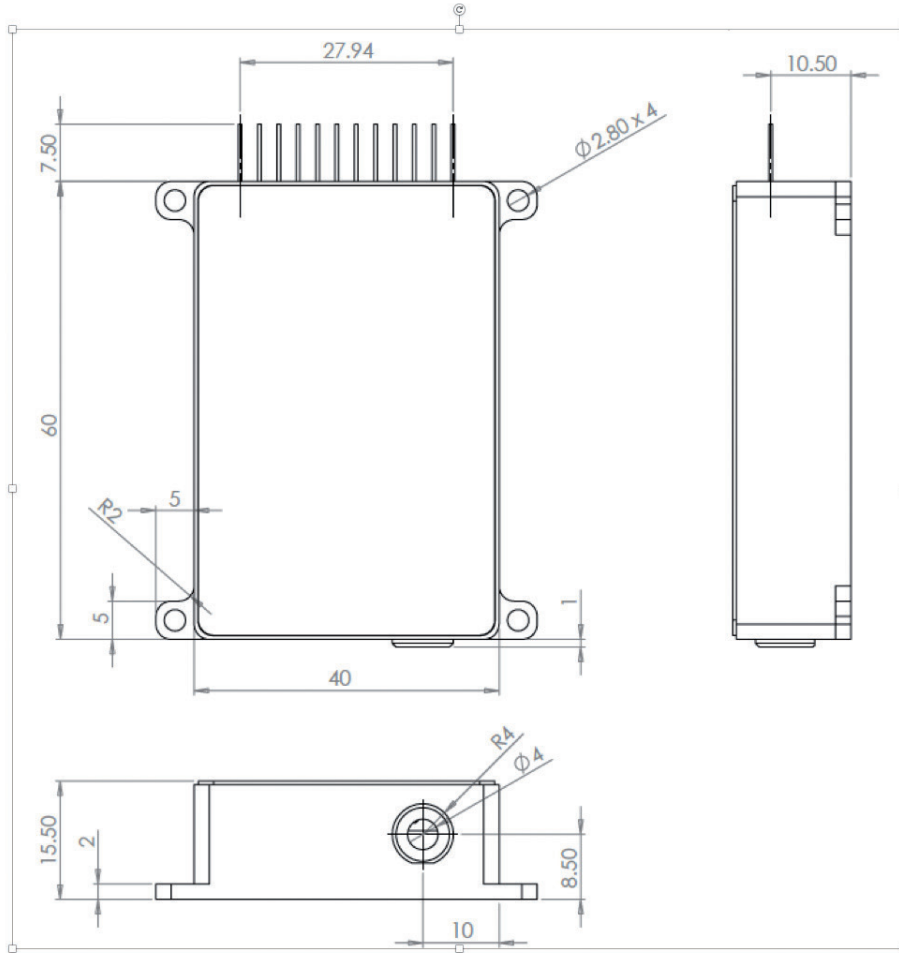

| Parameter | Value |
|-----------------------------|---------------|
| Wavelength | 780.24 nm |
| Linewidth | < 500 kHz |
| Output power | >150mW |
| Beam diameter | <0.5mm FWHM |
| Beam divergence | <1mrad FWHM |
| Polarization | Linear, 100:1 |
| Warm-up to stable operation | <10 minutes |